

X:\Projects\SDP-14000\Land\Construction Drawings\SDP14000-XS1.dwg, 9/1/2016 3:13:57 PM, Hughes, Kevin

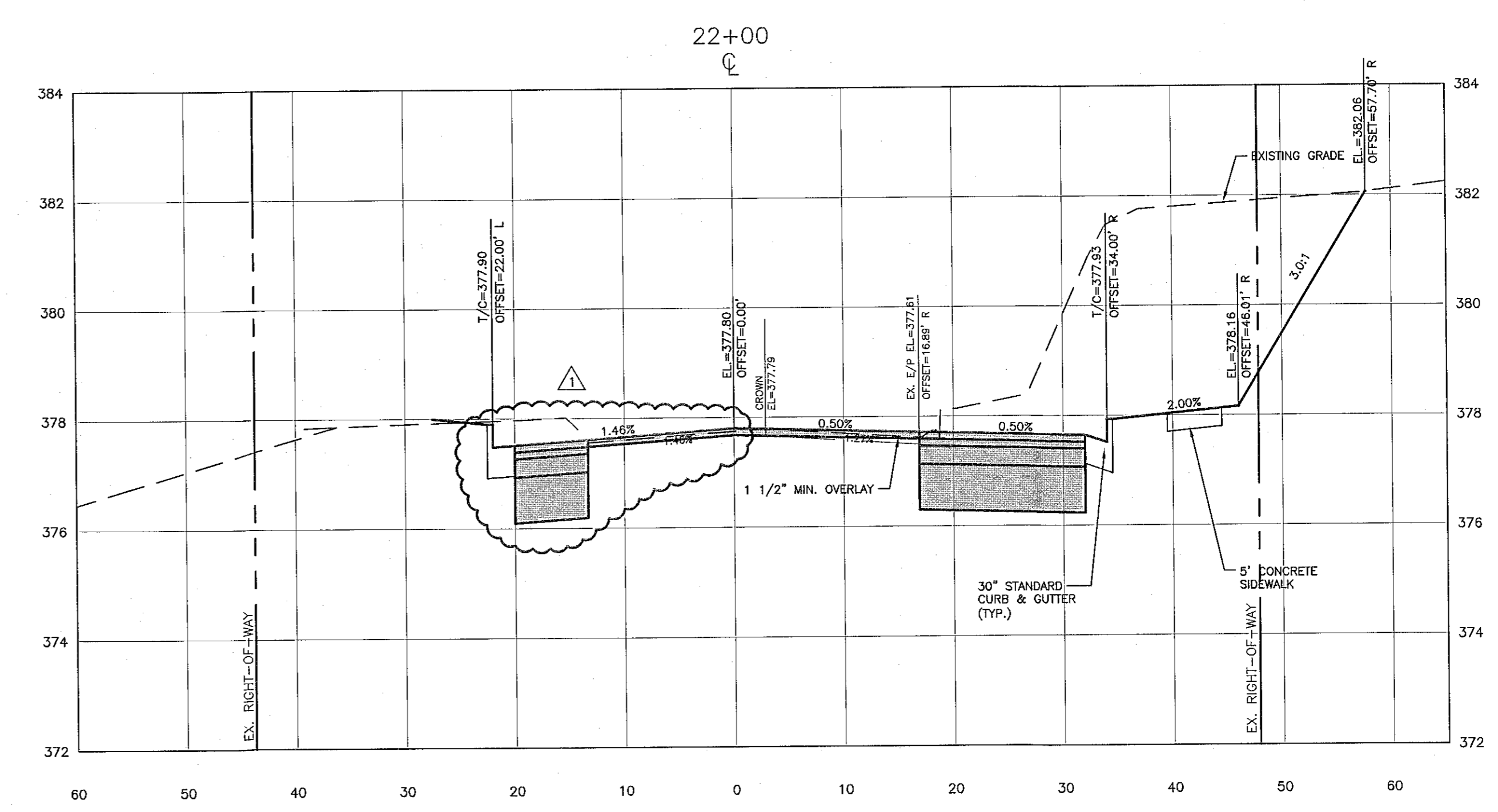
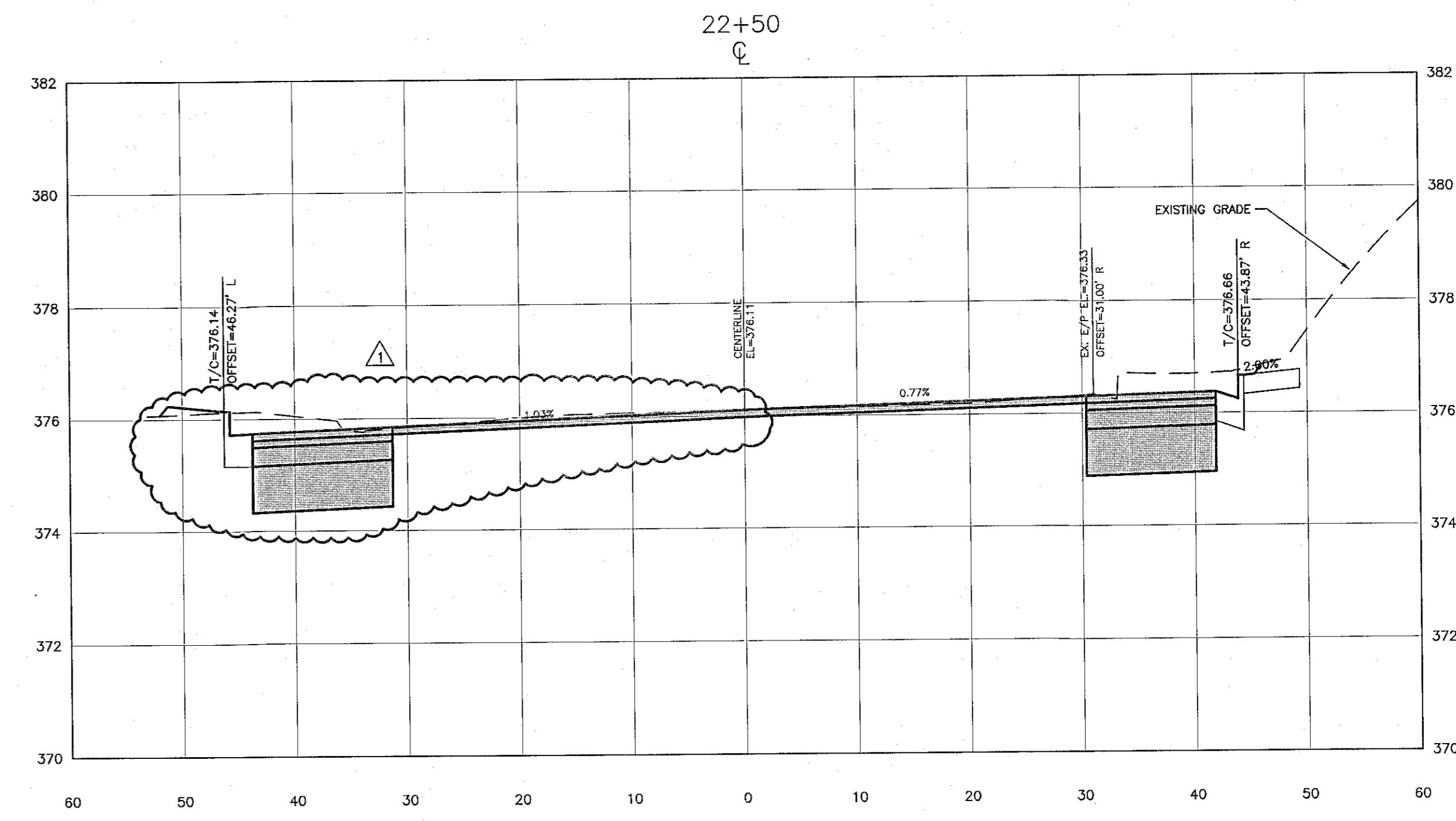

15-SB-006A
 HTE#: 15-1352
 APPROVED BY THE TOWN OF CARY
 DEVELOPMENT REVIEW COMMITTEE

Planner: DRL Date: 10/4/16

FINAL DRAWING - RELEASED FOR CONSTRUCTION

REVISIONS:

2016-08-31	REVISED TO SHOW FULL BUILDOUT

DEVELOPER:
 STANDARD PACIFIC HOMES, LLC.
 1100 PERIMETER PARK DR, SUITE 112
 MORRISVILLE, NORTH CAROLINA 27560



THE JOHN R. McADAMS
 COMPANY, INC.
 2905 Meridian Parkway
 Durham, North Carolina 27713
 License No.: C-0293
 (800) 733-5646 • McAdamsCo.com

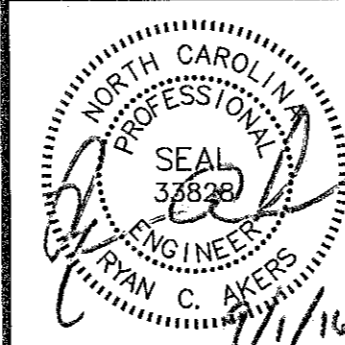

PROJECT NO.	SDP-14000
FILENAME:	SDP14000-XS1
CHECKED BY:	MDS
DRAWN BY:	KWH/MDS
HORIZ. SCALE:	1" = 10'
VERT. SCALE:	1" = 2'
DATE:	03-10-2016

CROSS SECTIONS
 INDIAN WELLS ROAD STA. 22+00 THRU STA. 22+50

BLAKELEY
 OFF-SITE CONSTRUCTION DRAWINGS
 CARY, NORTH CAROLINA

SHEET NO. **XS-7**
 MCADAMS
 PRINT DATE: