

REVISIONS	BY
6-12-00 PER TERMS OF CONTRACT	CEK
7-14-00 PER TERMS OF CONTRACT	CEK
7-14-00 FOR LANDSCAPE PLANS	CEK
7-14-00 PER TERMS OF CONTRACT	CEK
9-12-00 ADD SS ENCASUREMENTS	CEK

**O'BrienAtkins**  
 ARCHITECT/ENGINEER/INTERIOR DESIGN/LANDSCAPE ARCHITECTURE/PLANNING  
 559 Jones Franklin Road  
 Suite 164-A  
 Raleigh, N.C. 27606  
 (919) 851-1912  
 (919) 851-1918 (FAX)

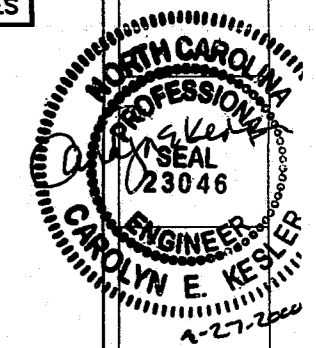

SEE SHEET C-2.0 FOR GENERAL NOTES



SITE UTILITY PACKAGE  
**CISCO SYSTEMS, INC.**  
 BUILDINGS 10, 11, & 12 RESEARCH TRIANGLE PARK, N.C.

DATE	4/21/00
SCALE	AS SHOWN
DRAWN	RF
JOB	09467.00
SHEET	C-84

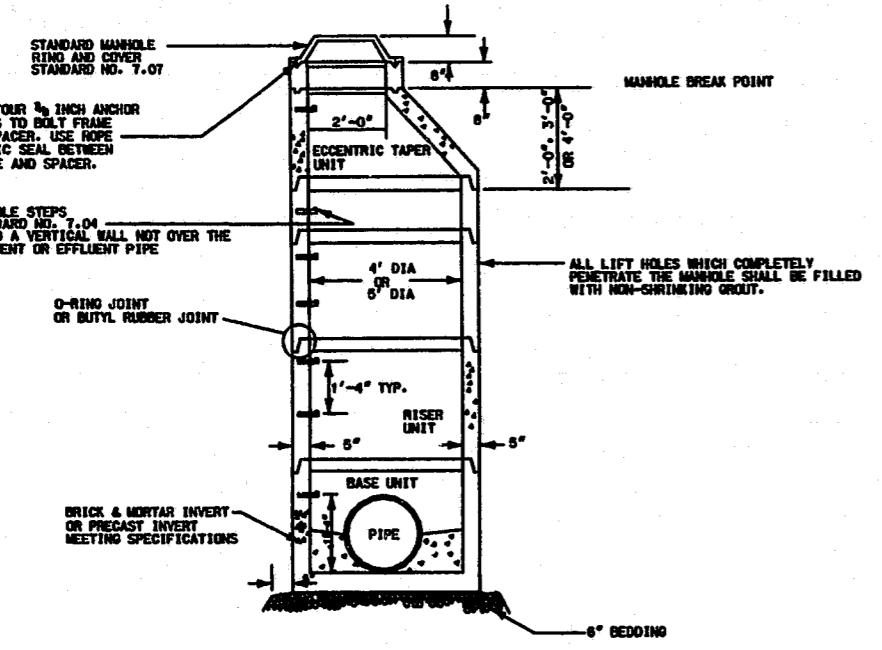

**STANDARD PRECAST CONCRETE MANHOLE**  
 NTS  
 NOT TO SCALE

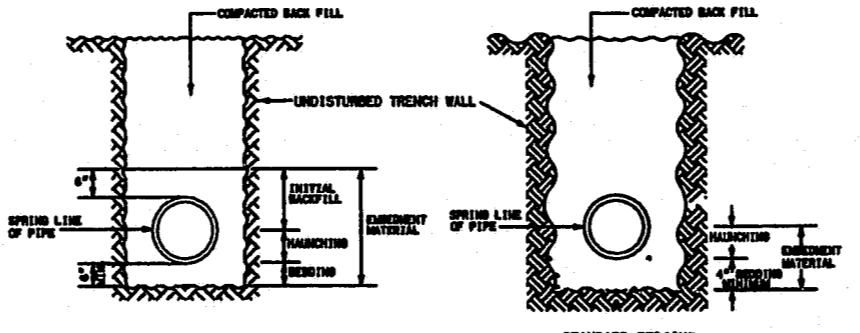

**NOTES:**  
 1. EMBEDMENT MATERIAL MUST BE CLASS 1 (IND. 67 OR 68-100 BORED STONE IS TYPICALLY USED).  
 2. EMBEDMENT MATERIAL SHALL BE COMPACTED TO A DENSITY OF 95% STANDARD PROCTOR DENSITY FOR CLASS 1 MATERIAL.  
 3. REFER TO SECTION 7-010 FOR EMBEDMENT MATERIAL SPECIFICATIONS.  
 4. ALL SANITARY SEWER LINES OVER 20 FEET IN DEPTH MUST BE 0-1-P.

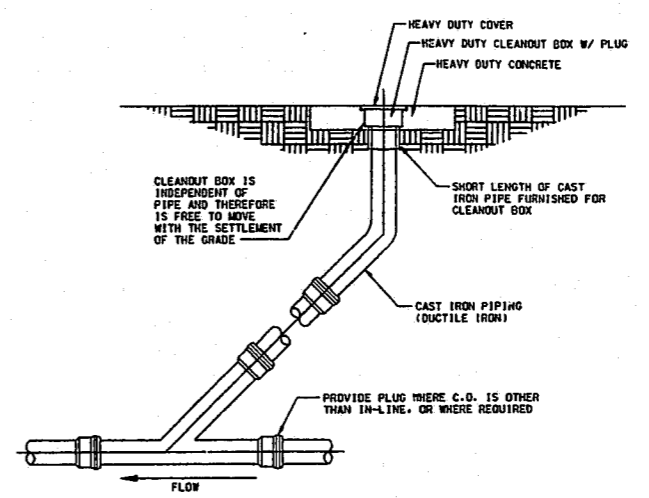

**STANDARD CLEANOUT**  
 NTS  
 NOT TO SCALE

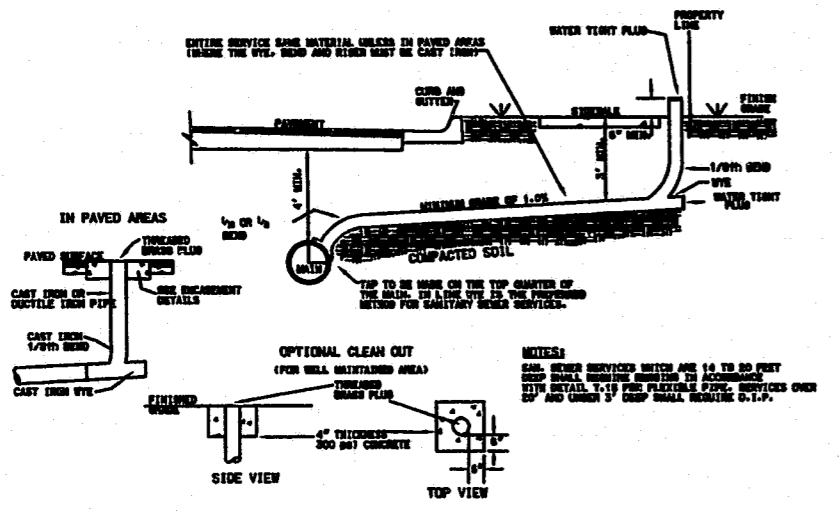

**STANDARD SANITARY SEWER TAP + SERVICE**  
 NTS  
 NOT TO SCALE

**BEDDING FOR FLEXIBLE + SEMI-RIGID SANITARY SEWER PIPE**

NTS  
 NOT TO SCALE

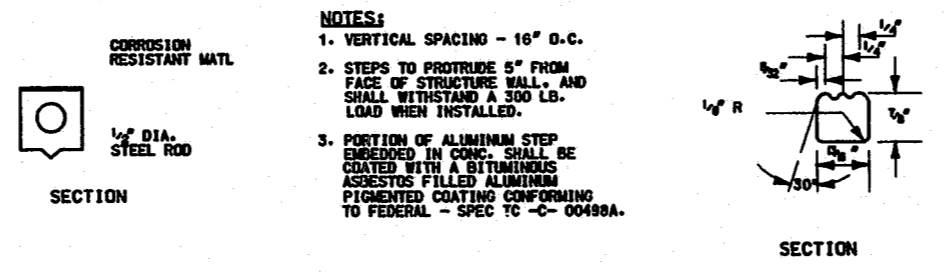

**NOTES:**  
 1. VERTICAL SPACING - 16\"/>

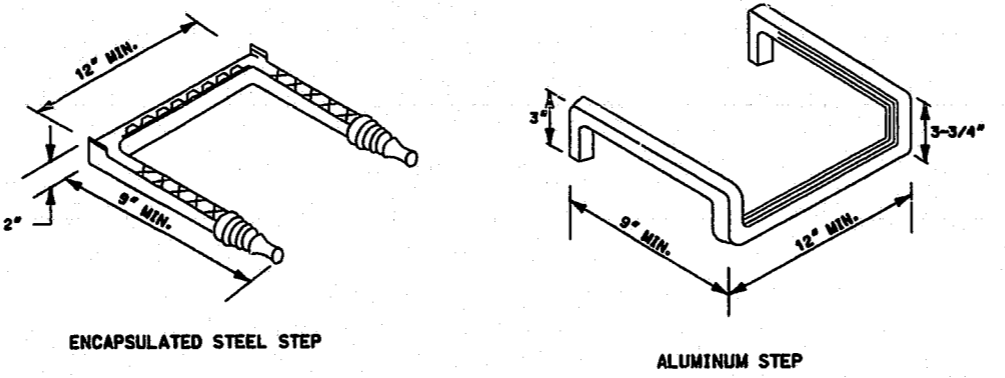

**MANHOLE STEPS**  
 NTS  
 NOT TO SCALE

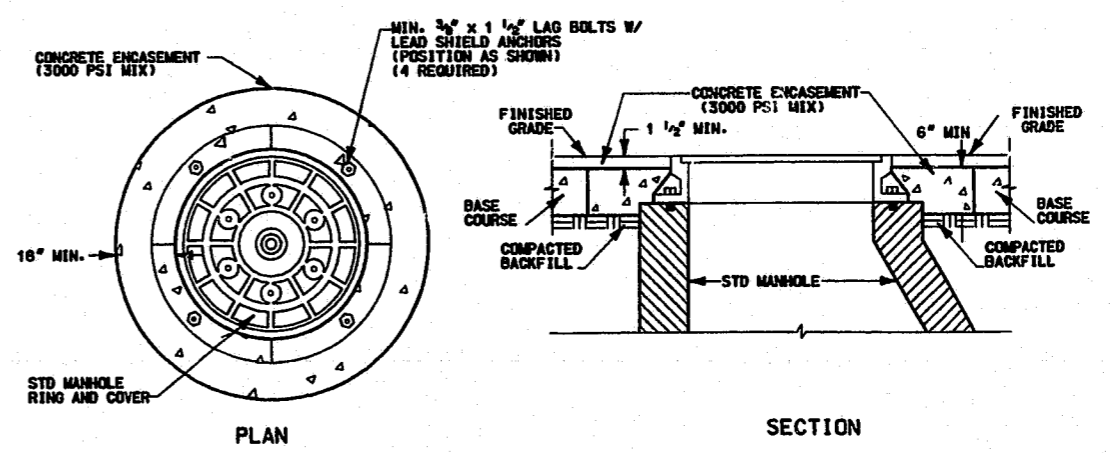

**NOTES:**  
 MANHOLE RING TO BE BOLTED AS SHOWN W/RUBBER MASTIC SEAL BETWEEN FRAME & SPACER.

**STANDARD MANHOLE RING AND COVER ENCASEMENT**  
 NTS  
 NOT TO SCALE

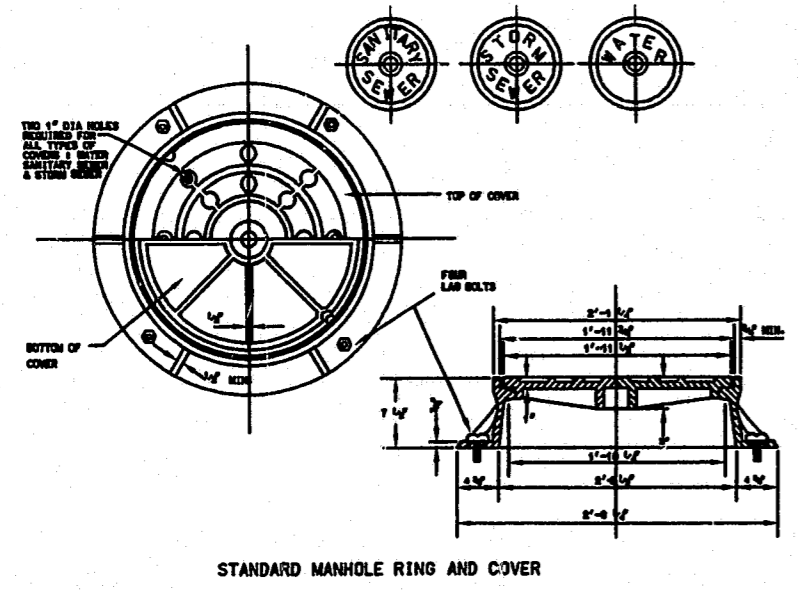

**STANDARD MANHOLE RING AND COVER**  
 NTS  
 NOT TO SCALE

The Engineer does not guarantee that all existing facilities such as gas lines, electrical lines, conduits, telephone cables, service connections, or other facilities are shown on the Plans. It shall be the Contractor's responsibility to have all utilities located by their respective owners, field mark the utility locations, and protect all such existing facilities prior to beginning construction. The Contractor is fully responsible for notifying all utility owners in accordance with NC General Statute - Chapter 87, Article 8, The Underground Damage Prevention Act.

**APPROVED**  
 RF  
 4/21/00  
 082-205400

**DETAILS**