

PLAN

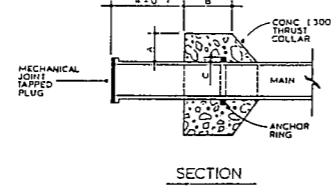

SECTION

SCHEDULE				
PIPE DIAMETER	CONCRETE THRUST COLLAR	ANCHOR RING	RINGS REQUIRED	
6", 8", 12"	1'-0"	1'-0"	2"	ONE
16"	1'-4"	1'-0"	2"	ONE
20"	1'-4"	1'-0"	3"	TWO
24"	1'-4"	1'-0"	4"	TWO
30"	1'-4"	1'-0"	4"	TWO

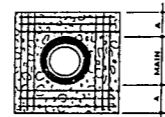

REINFORCING

1 THRUST COLLAR INSTALLATION

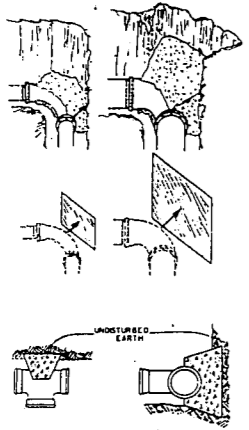

NOM. PIPE DIA. (IN)	MINIMUM CONCRETE BLOCKING (C.Y.)*					
	TEES & DEAD ENDS	90° BEND	45° BEND	22/27° BEND	11/4° BEND	
4	1/3	1/3	1/3	1/3	1/3	1/3
6	1/3	1/3	1/3	1/3	1/3	1/3
8	1/3	1/2	1/3	1/3	1/3	1/3
10	2/3	3/4	1/2	1/3	1/3	1/3
12	3/4	1.0	2/3	1/3	1/3	1/3
14	1.0	1 1/4	3/4	1/2	1/3	1/3
16	1 1/3	2.0	1.0	1/2	1/3	1/3
18	1 2/3	2 1/3	1 1/3	2/3	1/3	1/3
20	2.0	3.0	1 2/3	3/4	1/2	1/3
24	3.0	4 1/3	2 1/3	1 1/3	2/3	1/3

\* CONCRETE SHALL BE 3000 PSI MIN.

NOTE: 1) NO UNDISTURBED SOIL COVER ENDS ARE PERMITTED  
2) CURB OR BLOCKING SHALL BE USED INSTEAD OF ALL OTHER WORK

2 THRUST BLOCKING

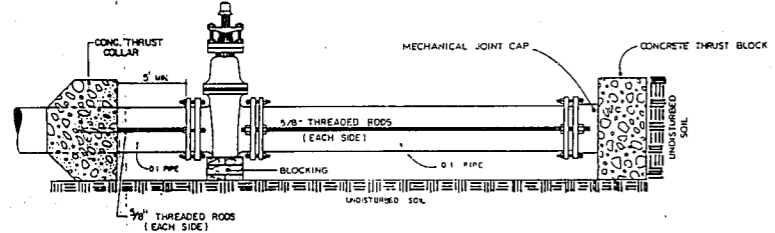

3 CAPPING DETAIL

NTS

NOTE: TOP OF BLOCKING TO BE 2" FROM HYDRANT KEEP HOLDS

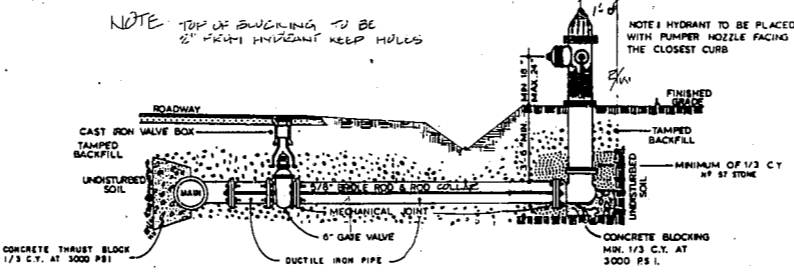

NOTE: HYDRANT TO BE PLACED WITH PUMP NOZZLE FACING THE CLOSEST CURB

4 HYDRANT INSTALLATION

NOTE: FIRE HYDRANT ASSEMBLY CALLED FOR IN RFD FORM INCLUDES TEE, BLOCKING, VALVE, LEG, & ALL OTHER NECESSARY ACCESSORIES

NTS

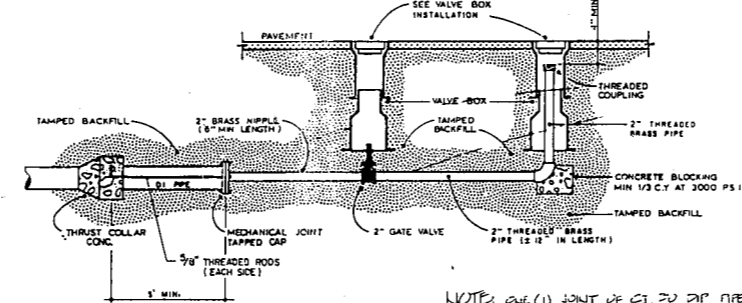

5 2\"/>

NTS

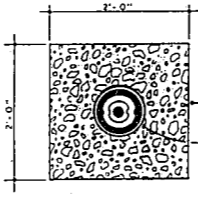

PLAN

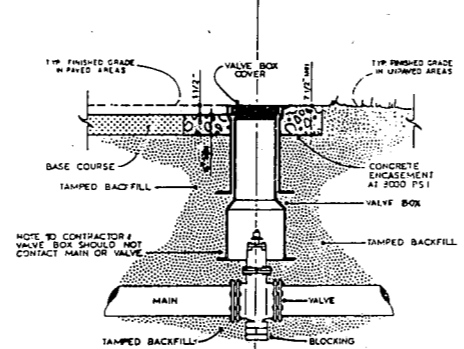

SECTION

6 VALVE BOX INSTALLATION

NTS

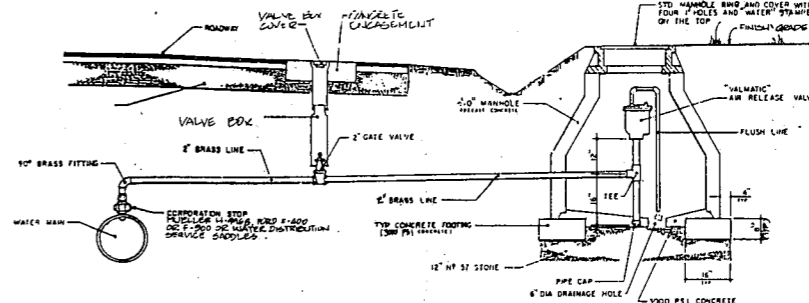

NOTE: CORPORATION STOP SHALL BE LOCATED IN THE TOP OF WATER MAIN

7 AIR RELEASE VALVE & MANHOLE

NTS

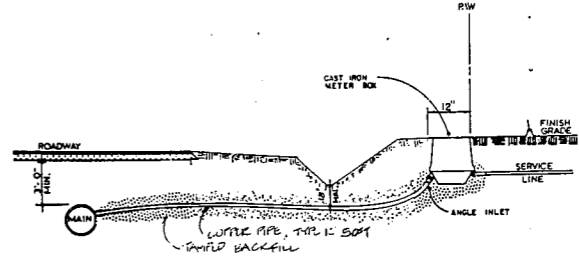

8 3/4\"/>

NTS

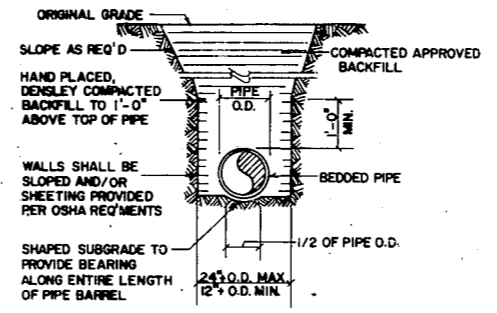

9 PIPE LAYING CONDITION

NOTE TO CONTRACTOR: ALL PAVEMENT CUTS SHALL BE REQUIRED WITHIN A MAXIMUM OF SEVEN (7) DAYS FROM THE DATE THE CUT IS MADE, IF CONDITIONS DO NOT PERMIT A PERMANENT REPAIR WITHIN THE GIVEN TIME LIMIT, PERMISSION TO MAKE A TEMPORARY REPAIR MUST BE OBTAINED FROM THE TOWN ENGINEER

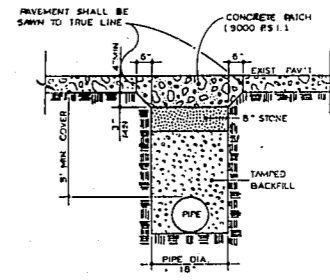

CONCRETE PAVEMENT

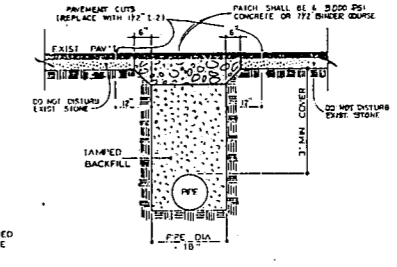

ASPHALT PAVEMENT

10 TRENCH & PAVEMENT REPAIR SECTIONS

NTS

**Dewberry & Davis**  
Engineers Architects Planners Surveyors  
Twin Forks Office Park  
5922 Six Forks Road  
Raleigh, N.C. 27609  
Tel. 867-0418

TRACT R-10  
PARKWAY P.U.D. CARY, N.C.  
OWNERS  
RICHLAND PROPERTIES, INC.

STANDARD WATERLINE  
DETAILS

Scale  
NO SCALE  
Sheet  
**12**  
Date  
File Number